

# Sigtronics SPCC-2 Communication Controllers

## OPERATING INSTRUCTIONS Models SPCC-2, SPCC-2+2, and SPCC-2+2T



### INTRODUCTION

The Sigtronics Portable Communications Controller (SPCC) provides a pilot/observer "mission team" with the ability to transmit and receive on multiple transceivers simultaneously; talk to each other via a voice activated (VOX) intercom; and monitor a third audio source. All these features, plus its portability, make it ideal for the airborne or the ground mission team!

**Typical Radio Configurations:** Use with your aircraft radios (permanently installed or hand-held models) and an additional "FM" transceiver. A typical "FM" radio transceiver would be: business band, police, ham, CB, flight phone, hand-held aircraft, marine, etc. (Some of these are actually AM radios, however they can be used).

**Dual Audio Panel** capability allows each headset position to select which radios to transmit and

receive on - independent of the other headset. Each headset position has dual volume controls, one for radio reception, and the other for their intercom volume level.

**Voice Activated Intercom** feature allows "hands-free" communication between headsets connected to the SPCC. Start speaking and the intercom instantly turns on to relay your message clearly to the other headset. Stop talking and it turns off to reduce background noise.

**Auxiliary Input** lets you monitor a third audio source, such as a police scanner, music source, etc.

**Portable** design gives flexibility and eliminates expensive installation costs. Especially useful to small departments that rent or lease. Or if a scheduled aircraft is down, the SPCC can be used in an alternate aircraft.



**Specialists in "SOUND" Management**

178 East Arrow Highway, San Dimas, CA 91773 ( 909 ) 305-9399

**TECHNICAL HIGHLIGHTS** which make the SPCC unbeatable are:

**Fail-Safe Bypass Switch** allows the pilot to operate the aircraft radios even if the unit is turned off.

**Automatic Sidetone Generation** lets the pilot and copilot hear what the other is transmitting over the radios.

**Separate Transmitter Microphone Gain Adjustments** adjust the aircraft radio and the FM radio.

**Excellent RF Immunity** guarantees clean, clear transmissions.

**Power Requirements:** A standard cigarette lighter socket (11 to 34 VDC) or a battery pack.

**Standardized** to general aviation headsets and portable push-to-talk switches. (The unit can also be wired into permanently installed PTT switches). Helicopter headsets will also work with the unit if headset plug adapters are used.

## APPLICATIONS

- **Airborne Law Enforcement** - Small police departments to large organizations like the FBI.
- **Civil Air Patrol/Coast Guard** - Air search and rescue operations.
- **Medevac Helicopters** - Medical emergency aircraft
- **Airborne Fire Control**
- **Forestry Departments**
- **Wild Life Organizations** - Survey and tracking operations
- **TV News Crews**
- **Airborne Traffic Reporters**
- **Ground Operations** requiring more than one radio.
- **Additional aircraft VHF radio capability** - Add an inexpensive hand-held aircraft radio as a second radio without installation costs.

## CONTROL FUNCTIONS

**ON / BYPASS** - Power Switch - In "ON" position; supplies power to all SPCC circuits. In "BYPASS" position; disables all unit functions, and connects pilot directly to the aircraft radios. A fail-safe feature!

**VOL** - Intercom Volume - Adjusts intercom volume level.

**SQ** - Intercom Squelch - Adjusts VOX operation of the intercom for variations in headset microphones and background noise levels.

**XMIT SELECT** - Transmit Select - Used to select which radio to transmit on.

**BOTH / OFF / AUTO** - Receive Select - Used to select which radio is heard. In "BOTH" position, you hear both aircraft and FM radios. In "OFF" position, you do not hear either radio. In "AUTO" position, only the radio selected by the XMIT SELECT switch is heard.

**AUX / OFF** - Auxiliary Select - Turns the auxiliary input source on or off.

**REC VOL** - Receive Volume - A general control used to set the volume level of the aircraft radio(s), FM radio, and the auxiliary monitor input.

**A/C RADIO MIC GAIN ADJ** - Aircraft Radio Microphone Gain Adjustment - Sets the transmit mic audio level for the aircraft radio(s).

**FM RADIO MIC GAIN ADJ** - FM Radio Microphone Gain Adjustment - Sets the transmit mic audio level for FM radio.

## SPCC INSTALLATION

The SPCC requires six simple connections to put it into operation. The power cord, the aircraft radio, the FM radio, the auxiliary audio input source (optional), the push-to-talk switches, and the headsets must all be connected for the system to work as designed. But do not fear, Sigtronics has simplified the connection process, so it will just take a few moments. Refer to the SPCC connection drawing Figure 1 on page 3.

1. **Power Cord:** The four foot power cord with *LED Power Indicator* is designed to plug directly into a standard cigarette lighter socket. The LED indicator will be on if power is available, it will be off if no power or reversed socket wiring. **Note:** The LED shows power available, not SPCC On or Off. The SPCC will run on 11-34 VDC, so it automatically adjusts to 12 or 24 volt aircraft. The SPCC can

FIGURE 1

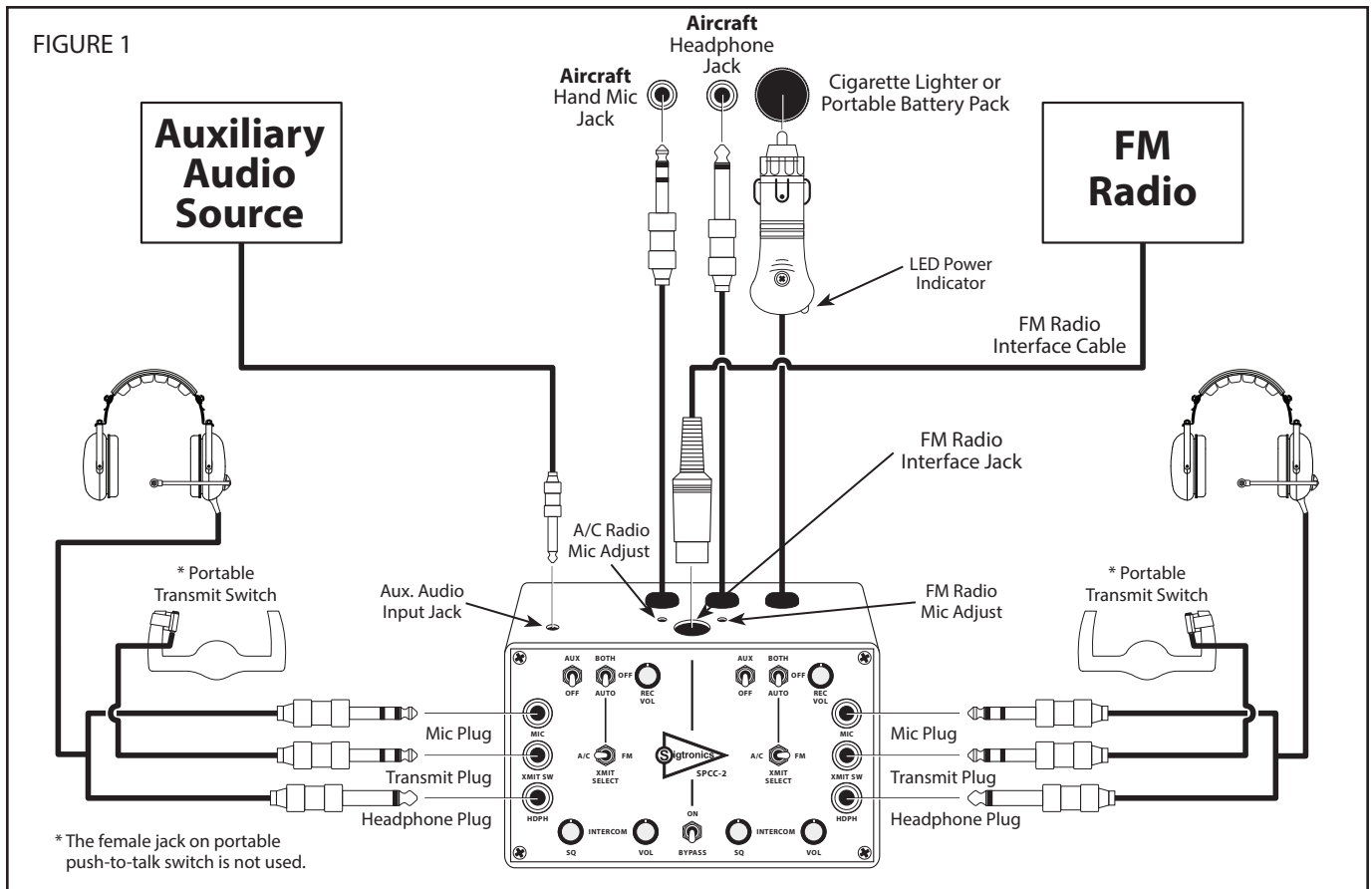

also be powered by an auxiliary battery pack, if desired.

2. **Aircraft Radio:** The mic and headphone cords on the unit are designed to plug into the mic and headphone jacks in the panel of the aircraft. If the aircraft does not have either one of these jacks, they can be installed by any qualified avionics technician. If you plan to use the SPCC in a helicopter, please contact Sigtronics for advise on adapting the general aviation plugs to the helicopter jacks.
3. **FM Radio:** An interface cable is needed to connect the SPCC to the FM radio. On one end of the cable will be a five pin connector to plug into the jack on the top of the SPCC. On the other end will be whatever is required by your FM radio. Since virtually any radio can be used and there is little standardization among manufacturers, no one cable will work for all radio transceivers. Therefore, the FM radio interface cable will have to be fabricated for your particular radio. This cable can be supplied to you by Sigtronics or made up by your radio technician. If you decide to purchase a completed interface cable, Sigtronics

has an extensive cable making facility and can provide you with one at minimum cost. We will need to know what length cable you require and the manufacturer and model number of the radio you wish to use.

If you would rather have your radio technician make the cable, the FM radio interface cable connector pin assignments and some typical cable wiring examples are located on page 7. A five pin connector plug is supplied with each SPCC unit for this purpose. You will also need the radio mating connector and connection schematic or hook-up drawing for your particular FM radio. These can usually be obtained from the radio manufacturer.

4. **Auxiliary Radio:** If you are using an auxiliary radio, then a simple interface cable is also needed to connect the SPCC to the auxiliary audio input source. The SPCC accepts a standard 1/8" monaural mini plug.
5. **Push-to-Talk Switches:** In order for pilot and observer to transmit on their selected radios, they will each need a push-to-talk (PTT) switch. The SPCC is compatible with all standard general aviation type portable push-to-talk switches. The

male plug on the PTT switches plug directly into the XMIT SW jacks of the SPCC unit. If your PTT switches also have a female jack, it is not used. The pilot should strap the switch end of his portable PTT switch to the yoke or stick of the aircraft. The observer's PTT can similarly be strapped to the co-pilot controls or operated as a hand-held switch. Various types of push-to-talk switches are available from Sigtronics, including one that does not have the female jack.

If you already have permanently wired push-to-talk switches in the aircraft, and wish to use them with the SPCC instead of the portable type, then wiring modifications will have to be made to the aircraft. Again, your avionics technician should be able to do this for you.

**6. Headset Hookup:** All standard general aviation headsets are compatible with the SPCC unit. Helicopter type headsets can also be used if adapter cables are used. (Sigtronics manufactures cables that adapt the helicopter plugs to general aviation plugs).

Plug the microphone and headphone plugs on the headsets into the jacks labeled MIC and HDPH, on the front panel of the SPCC. Put on the headset, and position the boom mic close to the mouth, as is the practice with hand-held microphones. Voice clarity is best when the mic is about 1/4" away and slightly off center from the lips. Turn headset volume control(s), if any, all the way up.

### INITIAL SYSTEM CHECK-OUT

The following System Check-Out will provide you with a "personalized" system. Perform the next few steps while on the ground to assure that all functions on the unit and radios are set to your personal hearing and speaking comfort.

**CAUTION** - As is standard practice with all aircraft equipment, be sure that the radio(s) and the SPCC are turned OFF when you start up the aircraft engine.

1. To assure that the aircraft radios, and pilot's headset and PTT switch are connected and functioning properly, put ON/BYPASS switch into "BYPASS" position. Then turn on the aircraft radios, and verify that the pilot can hear the radios and can transmit using his push-to-talk switch and headset. All other intercom functions should be inoperable in the BYPASS mode.

2. Intercom operation and adjustment can be performed by the following procedure:

- A. First set the ON/BYPASS switch to the "ON" position and turn both REC VOL controls all the way down (counterclockwise).
- B. Turn both intercom volume controls to the 9 o'clock position and both squelch controls all the way up (clockwise). Notice the intercom is now continually activated and you should be able to talk between headsets.
- C. To adjust the intercom squelch controls for voice activated operation (VOX), it is helpful to have some background noise present. It may also be necessary to turn up the intercom volume controls. Turn both intercom squelch controls all the way counterclockwise. Now, without speaking, rotate one of the squelch controls clockwise until you hear the background noise in your headset. Next, using that same control, rotate counterclockwise small, incremental amounts until the background noise disappears. (This procedure is necessary because the squelch is a "fast on, slow off" system). That squelch control is now set.
- D. Adjust the other intercom squelch control similarly by turning it clockwise until you hear background noise. Rotate counterclockwise incremental amounts until the background noise disappears.

Small adjustments may be necessary if aircraft background noise changes significantly - such as from idle to full power.

3. Radio Selection of both the aircraft and the FM radios is provided by two switches.

- A. XMIT SELECT determines the radio you wish to transmit on.
- B. AUTO/OFF/BOTH selects which radios you receive in your headset.
  - i. "AUTO" position allows you to hear the radio that the XMIT SELECT switch is set to.
  - ii. "OFF" prevents you from hearing either radio.
  - iii. "BOTH" position permits you to hear both the aircraft radio(s) and the FM radio at the same time.

4. The AUXiliary audio source is selected by the AUX/



OFF switch. In the "AUX" position, you can hear it, and in the "OFF" position you cannot.

5. Receive Volume Controls (REC VOL) are general volume controls, meant to provide overall listening level for all three radios simultaneously - A/C, FM, and AUX. Finite volume adjustments of any individual radio should be done by altering the radio volume control at the radio itself.

### SYSTEM OPERATION

Once the radios are selected, pilot or observer can transmit at any time simply by pressing their PTT switch. When one position transmits, several things take place automatically to the transmitting side of the SPCC:

- The intercom between the two positions is turned off.
- The Auxiliary audio, if selected, is muted.
- The receive audio of the radio not selected by the XMIT SELECT switch is muted, regardless of the position of the AUTO/OFF/BOTH switch.
- The selected radio is put into transmit mode.
- The headset microphone audio (your voice) is sent to the selected transmitter.
- Sidetone is generated and sent to your headphones.\*

\* Sidetone is a portion of the transmitted voice signal sent back into your headset, so that you can hear what you are saying while transmitting. The REceive VOLume control adjusts the volume level of the sidetone that you hear in your headset. If the AUTO/OFF/BOTH switch is in the "OFF" position however, you will not hear this sidetone.

The non-transmitting side is not affected (except for intercom) when the other side transmits. The non-transmitting side can monitor the transmissions of the other side by simply selecting the same radio on his side of the SPCC. Of course, when the PTT switch is released, (stop transmitting) all functions return to normal, instantly and automatically.

Simultaneous Transmit is the most attractive and powerful feature of the SPCC. Both pilot and observer can transmit at the same time - either on separate radios or on the same radio transmitter! When on different radios, the pilot and observer will not interfere with each other's communications.

For example, the pilot can talk to air traffic control while the observer talks on the FM radio to the ground crew, or vice versa. On the other hand, they can also transmit on the same radio transmitter. If, for example, the observer is talking on one of the radios, the pilot can jump right in and add to the conversation simply by pressing his PTT switch. Both voices will be heard by the receiving station.

**NOTE:** Only the aircraft radios and the FM radio can be transmitted on. The AUXiliary input is for listening only. It can be used for listening to a police scanner, monitoring the audio portion of a video camera, listening to background music, and many other possibilities.

### TRANSMIT MICROPHONE GAIN ADJUSTMENTS

Transmit microphone gain adjustments for both the FM and the aircraft radios are provided through two small holes on the top of the SPCC unit. These adjustments set the microphone audio level going to the radios during transmit. Adjustment should be made only if the outgoing radio transmissions are reported as weak or garbled. The Aircraft Radio Mic Gain Adjustment is set at the factory for standard aircraft radios and should not need any adjustment. The FM Radio Mic Gain Adjustment, however, will more than likely need to be initially set to your particular FM radio. This level, once set, should never need adjustment again unless, of course, the type of FM radio used is changed. The following simple procedures take you through the adjustment of the FM and A/C mic gain levels. If desired, a qualified radio technician can do this for you.

**FM Radio Mic Gain Adjustment can** be made through the hole to the right of the FM radio interface connector with a small, flat bladed screwdriver. The basic adjustment concept is simple. You will be setting the level and clarity of outgoing transmissions of the FM radio, when it is hooked up through the SPCC, to match or exceed that of transmissions on the radio when it is not connected to the SPCC. To do this, you will need to transmit and receive on the FM radio to a remote station. Arrange to have someone nearby with a radio compatible to the FM radio you are using with the SPCC. Then . . .

1. Set the **ON/BYPASS** switch to the "**BYPASS**" position and connect the SPCC up to power, as normal. Plug in the observer's PTT switch and

headset. Do not connect the FM radio to the SPCC at this time. (It is not necessary to connect the A/C radios or the pilot's headset or PTT switch for this adjustment.) Set the observer's **XMIT SELECT** switch to "**FM**", the AUTO/OFF/BOTH switch to "**AUTO**", and the AUX switch to "**OFF**".

2. Set the SPCC aside for a moment. With the FM radio disconnected from the SPCC, transmit as normal, on the FM radio, to the remote station. Transmit long enough so that the receiving station can get "calibrated" to your transmission (voice) level.

3. Connect the FM radio to the SPCC as normal with the FM interface cable. Put on the observer's headset and turn the SPCC "**ON**". Verify FM radio reception. If OK, use observer's PTT to transmit to your receiving party. If receiving station reports weak transmission, use the screwdriver to turn the **FM MIKE GAIN ADJ** clockwise a small amount. If they report garbled or broken transmissions, turn the **FM MIKE GAIN ADJ** counterclockwise a small amount. Repeat as necessary until the receiving party reports that transmissions through the SPCC sound as good or better than when the FM radio is used separate from the SPCC. That's all there is to it!

The **A/C Radio Mic Gain Adjustment** is located to the left of the FM radio interface connector. Again, the A/C Mic Gain Adjustment, in most cases, will not have to be changed from its original factory setting. If however, your aircraft radio transmissions through the SPCC are reported as weak or garbled, you will need to reset this level. The adjustment procedure is similar to that of the FM mic gain adjustment above. You can, however, use the "**BYPASS**" mode of the SPCC to aid in the adjustment. Arrange to have someone with an aircraft radio nearby with whom you can transmit and receive. Then, proceed as follows:

1. Set the **ON/BYPASS** switch to the "**BYPASS**" position and connect the unit as normal to power and aircraft radios. Plug in the pilot's headset and PTT switch into the jacks on the left side of the SPCC. (The FM radio and observer's headsets and PTT switches are not needed for this adjustment.) On the pilot's side of the SPCC, set the **XMIT SELECT** switch to the "**A/C**" position, the **AUTO/OFF/BOTH** switch to "**AUTO**", and the **AUX/OFF** switch to "**OFF**".
2. Put on the pilot's headset. Transmit and receive to your nearby station, using the pilot's PTT switch and headset, as described in the Initial System Check-Out section on page 8. Verify good transmission and reception. In this mode you are bypassing the SPCC and verifying the clarity of the aircraft radios.
3. If radios check out OK, then turn the **ON/BYPASS** switch to the "**ON**" position. Verify aircraft radio reception. If OK, use the pilot's PTT to transmit to your receiving party. If the receiving station reports weak transmissions, use the screwdriver to turn the **A/C MIKE GAIN ADJ** clockwise a small amount. If they report garbled or broken transmissions, turn the **A/C MIKE GAIN ADJ** counterclockwise a small amount. Repeat as necessary until the receiving party reports that transmissions with the SPCC turned "**ON**" sound as good as that when the **ON/BYPASS** switch is "**BYPASS**" mode.

FM RADIO INTERFACE CABLE WIRING	
FM Radio Interface Cable Connector Pin Assignment	
Pin	Function
1	Mic audio output to FM radio
3	Receive audio input from FM radio
4	FM radio ground
2,5	Transmit key output to FM radio (Normally open relay contacts closed during FM radio transmit)

### FM RADIO INTERFACE CABLE WIRING

The following are some examples of possible wiring schemes for the FM interface cable. Only the FM radio functions are shown for the FM radio end of the interface cable, because the connector(s) used by radio manufacturers varies widely. You will have to consult the radio manual or manufacturer for the connector(s) used and pin assignments for your particular FM radio. Also, Sigtronics has extensive radio interface experience and can assist in any question you might have concerning this or any other aspect of the SPCC. Of course, Sigtronics can build a FM interface cable for you to your specifications, if desired.

**Figure 3** shows the most common of such cables with its "high level mic input" and standard "ground to key" interface. This cable will work with most standard police, fire, and business band radios as well as aircraft type radios.

**Figure 4** is similar to Figure 3 but is used for radios requiring a low level mic input such as marine type radios.

**Figure 5** shows typical cable wiring for radios that sense the presence of mic current to transmit. Most ICOM hand-held radios are set-up this way.

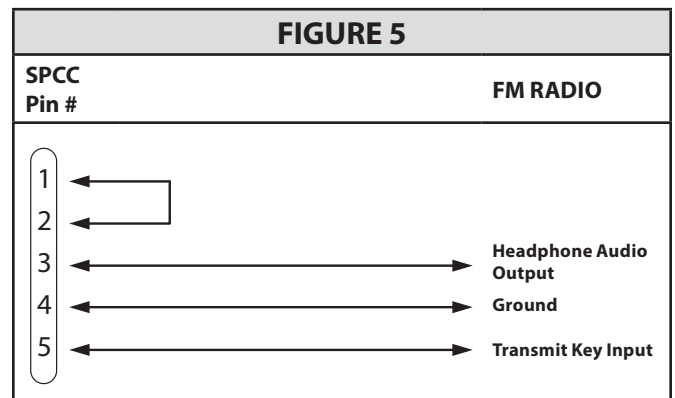
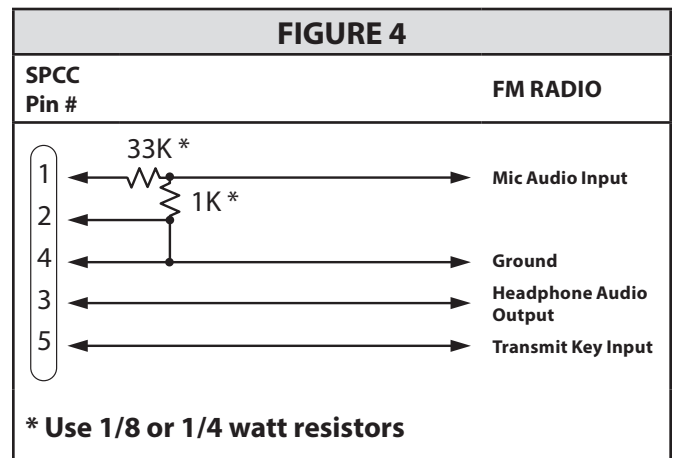
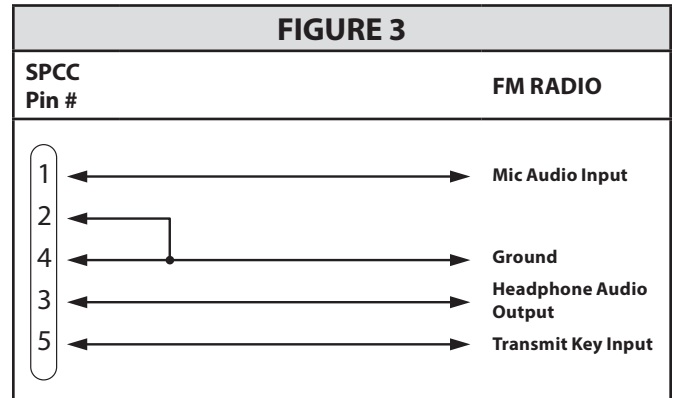
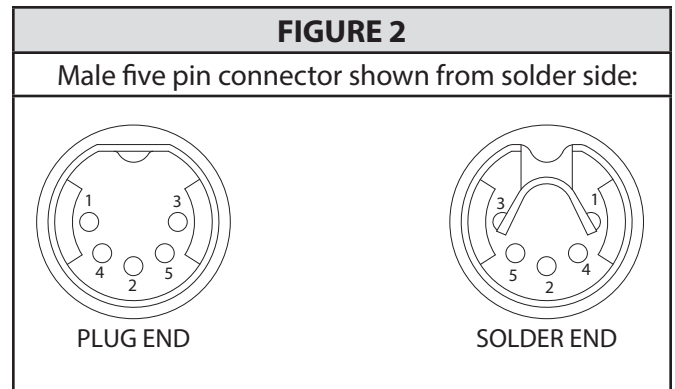

## **SPCC-2+2**

The +2 option allows for one or two additional headset positions to be added to the standard SPCC for intercom. This is ideal for training or if you need additional spotters or observers along on your missions. A small remote satellite unit is provided that connects to the main SPCC unit. This satellite unit comes standard with two sets of headset jacks and a four foot cable so that it can be placed in the back seat of the aircraft for convenience. The satellite unit is also detachable for those times you only need two positions. As well as full VOX intercom, the back two headsets also hear the radio(s) selected by the front observer's position. Similarly, the radio receive and intercom volume and squelch controls on the observer's panel also control the corresponding levels for the back two positions. These back two positions cannot transmit on any of the radios and their microphones are silenced whenever the observer presses his PTT switch to transmit. They will, however, hear what the observer is transmitting. All other functions for the pilot and observer positions operate just as with non +2 units.

## **SPCC-2+2T**

The +2T option operates just like +2 option (See above) except for one exception. The back two positions can transmit. They will only transmit on the radio that is selected on the observers side of the SPCC. Two additional jacks are provided on the satellite unit for portable PTT switches. One for each back position.

## **THREE YEAR WARRANTY**

Every Sigtronics' Product has been carefully inspected before shipment. We guarantee to correct any defect caused by faulty material or workmanship free of charge to the user who originally purchased the product per the enclosed warranty card. Our obligation assumed under this guarantee is limited to the replacing of any part or parts which prove to our satisfaction, upon examination to have been defective, and which have not been misused or carelessly handled. The complete unit must be returned to our factory, transportation charges prepaid. We reserve the right to decline responsibility where repairs or replacements have been made or attempted by others. No other guarantee, written or verbal, on our products is authorized by us.

Repairs required due to abuse, misuse, damage or normal service beyond the warranty period will be subject to normal service charges.

To expedite factory service work, write Sigtronics' Service Department and explain the problem. All correspondence relative to service work should include model and serial number. Frequently problems can be resolved by phone. Should you wish to call, our number is (909) 305-9399.

## **SPCC SPECIFICATIONS**

Input Voltage: 11-34 VDC

Nominal Current: 0.07 Amps

Maximum Current: 0.15 Amps

Weight: 22 oz.

Size: 3.75 x 6.25 x 2.5 inches

A/C Interface Cord length: 4 feet each

## **SIGTRONICS CORPORATION**

178 East Arrow Highway  
San Dimas, CA 91773

**Phone:** 909-305-9399

**FAX:** 909-305-9499

**Web:** [www.sigtronics.com](http://www.sigtronics.com)